

降电费·减碳排·降成本

SPS电盾能源站 产品说明书

REDUCING COST · DECREASING EMISSIONS · CUTTING EXPENSES
SPS SHIELD POWER STATION
PRODUCT INTRODUCTION



祥和节能集团

XIANGHE ENERGY-SAVING GROUP

成都祥和云端节能设备集团有限公司

CHENGDU XIANGHE CLOUD ENERGY SAVING EQUIPMENT GROUP CO., LTD

稳驾绿电波澜 保驭能效节流

NAVIGATE GREEN POWER WAVES
STEER ENERGY EFFICIENCY FLOW

SPS电盾能源站，是集发电、储电、稳电、用电四位一体的绿电微网系统。

面对光伏发电、风力发电等绿电的常规波动，或电网突发冲击，SPS均能有效保障用电设备稳定运行，为用户提供“盾牌级”高品质电能，破解新能源不稳定难题，助力实现电费节约、设备故障率降低及雷击风险抵御等。

SPS Shield Power Station is a green power microgrid system integrating power generation, power storage, power stabilization, and power consumption into a four-in-one system.

Whether facing routine fluctuations from green power sources such as photovoltaic and wind power generation, or sudden grid impacts, the SPS effectively ensures the stable operation of electrical equipment. It provides users with "shield-level" high-quality power, addresses the challenge of new energy instability, and helps achieve electricity cost savings, reduced equipment failure rates, and enhanced protection against lightning strike risks.

POWER EFFICIENCY



Power
Generation



Power
Storage



Power
Stabilization



Power
Consumption

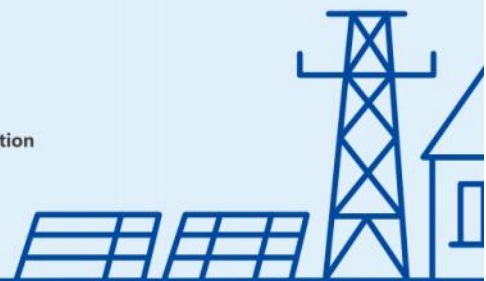

SPS电盾能源站 SHIELD POWER STATION



不稳定、不确定、不可控和波动大。

- Key Challenges of Green Power:
 - Intermittency: Unstable power output
 - Unpredictability: High forecasting uncertainty
 - Uncontrollability: Limited regulation capability
 - Volatility: Significant power fluctuations

导致电压波动、频率失衡、功率因数下降、线损增加、能耗上升等新问题。

- Resulting System-Level Problems:
 - Voltage fluctuations
 - Frequency imbalances
 - Decreased power factor
 - Increased line losses
 - Higher energy consumption

引发用电设备温度升高、振动增大、摩擦加重、噪声增大、废品率上升、维保成本增加、设备寿命缩短。

- Resulting Equipment-Level Problems:
 - Increased operating temperature and vibration
 - Friction losses and elevated noise levels
 - Higher product defect rates
 - Increased maintenance costs
 - Shortened equipment lifespan



CONTENTS

目录

01

适用场景 05

APPLICABLE
SCENARIOS

02

产品概述 07

PRODUCT
OVERVIEW

05

产品分类 14

PRODUCT
CATEGORIES

06

典型范例 17

TYPICAL
CASES



◆ 绿电发得出

Green Power is Reliable Generation

◆ 电网接得住

Green Power is Resilient Grid

◆ 终端用得好

Green Power is Efficient Consumption

03

核心功能

09

CORE
FEATURES

04

技术原理

12

TECHNICAL
PRINCIPLE

07

建设方案

23

SOLUTIONS

08

集团简介

25

GROUP
PROFILE

01 APPLICABLE SCENARIOS 适用场景



POWER CONSUMPTION SIDE 用电侧

适用于各类新建及现有配电系统，典型场景包括：
Applicable to various new and existing power distribution systems, typical scenarios include:



Precision Manufacturing 精密制造

芯片、电子、制药、食品、数控加工等行业，保障生产良率与设备安全。

Industries such as semiconductors, electronics, pharmaceuticals, food processing, and CNC machining, ensuring production yield rate and equipment safety.



Data Centers 数据中心

数据中心、算力中心等，防止数据丢失与设备异常宕机。

Data centers, computing centers, etc., preventing data loss and unexpected equipment downtime.



Public Transportation 公共交通

机场候车区、地铁车站、客运站、港口、码头、高速收费站与服务区、公路隧道等。

Airport waiting areas, subway stations, bus terminals, ports, docks, highway toll stations and service areas, road tunnels, etc.



Commercial Buildings 商业楼宇

商场、办公楼、学校、酒店、居民社区等，实现节能降耗与负荷平衡。

Shopping malls, office buildings, schools, hotels, residential communities, etc., achieving energy savings and load balancing.



Financial Trading 金融交易

银行、证券交易所等，确保交易系统不间断稳定运行。

Banks, stock exchanges, etc., ensuring uninterrupted and stable operation of trading systems.



Other Facilities 其他设施

石油石化、化工、医院、水务、矿山、油田、通用制造、图书馆、军事设施、应急设施、规模化养殖等。

Petrochemicals, chemicals, hospitals, water utilities, mines, oil fields, general manufacturing, libraries, military facilities, emergency facilities, large-scale farming, etc.

POWER
GENERATION SIDE
发电侧

适用于集中式光伏电站、集中式风电场、生物质发电站、抽水蓄能电站等。

Applicable to centralized photovoltaic power stations, centralized wind farms, biomass power plants, pumped storage power stations, and similar facilities.



集中式光伏电站
Centralized photovoltaic power station

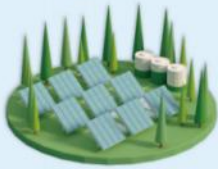

集中式风力电站
Centralized wind power station



生物质发电站
Biomass power station



抽水蓄能电站
Pumped storage power station

POWER
TRANSMISSION SIDE
输电侧

适用于各类调峰电站等应用场景。

Suitable for application scenarios such as various peaking power plants.



02

PRODUCT OVERVIEW

产品概述



Core Definition

核心定义

SPS电盾能源站（英文：Shield Power Station，简称SPS），是集发电、储电、稳电、用电四位一体的绿电微网基础设施。

区别于传统“光伏电/风电+储能”电站，SPS电盾能源站依托祥和抗冲调流（系统保护节能）型变压器或电保镖——反常安全保护装置，通过双向阻隔、削减、滤除、吸收四大机制，系统性地解决光伏电、风电等绿电因不稳定、不确定、不可控和波动大四大绿电固有缺陷，所引发的各类问题，提供定制化全链路电能质量解决方案。

SPS, or Shield Power Station is a green power microgrid infrastructure that integrates four core functions - power generation, power storage, power stabilization, and power consumption - into a four-in-one system.

Unlike traditional "photovoltaic/wind power + energy storage" stations, the SPS Shield Power Station leverages Xianghe's core technologies, including impact-resistant and current-regulating transformers (system protection and energy conservation type) or the "Xiang He Power Guard" – an abnormal safety protection device. Through four key mechanisms – bidirectional blocking, mitigation, filtering, and absorption – it systematically addresses various issues caused by the inherent shortcomings of green power (such as photovoltaic and wind power), namely their instability, unpredictability, uncontrollability, and significant fluctuations. The SPS provides customized, end-to-end power quality solutions.



SPS

携手祥和节能集团 开启SPS电盾能源站新纪元

PARTNER WITH XIANGHE ENERGY-SAVING GROUP
USHER IN A NEW ERA WITH THE SPS SHIELD POWER STATION

Modular Composition

模块构成

SPS电盾能源站以“新型优质电能模块、稳电模块、系统节能模块”为核心基础，支持“光伏发电/风力发电模块、现代储电模块”作为可扩展单元，可根据用户需求灵活配置、个性化部署。

The SPS is built upon a core foundation of the advanced and high-quality power services Power Module, Voltage Stabilization Module, and System Energy Saving Module. It supports the Photovoltaic Power Generation\Wind Power Generation Module and Modern Electricity Storage Module as expandable units, allowing for flexible configuration and personalized deployment based on user requirements.

Core Value

核心价值

SPS电盾能源站输出的绿电具备清洁、平稳、低冲击、低电污染等特性，是稳定可靠的新型优质电能，可为各类用电场景提供不低于传统市电品质的电力保障。

The green power output by the SPS features cleanliness, stability, low impact, and low electrical pollution. It represents a stable and reliable form of advanced and high-quality power, capable of providing a power guarantee for various electricity consumption scenarios that meets or exceeds the quality of traditional grid power.

Core Differentiation

核心差异

SPS电盾能源站与常规光伏电站、风力电站、储能电站及光储一体化电站的根本区别在于：常规电站侧重于绿电的电费降低“量”供应，而SPS电盾能源站更聚焦于绿电“质”的提升，其输出电能经过深度净化与稳定处理，有效消除绿电固有问题，实现真正的“新型优质电能”。

The fundamental distinction between the SPS Shield Power Station and conventional photovoltaic power plants, wind power plants, energy storage power plants, and integrated photovoltaic-storage stations lies in their primary focus. Conventional plants emphasize the "quantity" supply of green power for cost reduction, whereas the SPS Shield Power Station concentrates on enhancing the "quality" of green power. Its output undergoes deep purification and stabilization processes, effectively eliminating the inherent issues of green power and delivering truly "new, high-quality electric power."

03

CORE FEATURES 核心功能



双向电能污染隔离

Bidirectional Power Pollution Isolation

SPS电盾能源站依托祥和抗冲调流型变压器或电保镖——反常安全保护装置的双向“防火墙”阻隔机制，一方面阻止电网侧瞬流、浪涌、谐波侵入用户端，另一方面防止用户设备产生的电能污染回馈电网，有效避免内外电能相互干扰、相互冲击与相互叠加。

Relying on the bidirectional "firewall" blocking mechanism of the Xianghe's impact-resistant current-regulating transformer or the Xiang He Power Guard—an Abnormal safety protection device—the SPS prevents grid-side transients, surges, and harmonics from intruding into the user side on one hand, and blocks power pollution generated by user equipment from feeding back into the grid on the other. This effectively avoids mutual interference, impact, and superposition between internal and external electrical power.



绿电波动智能缓冲

Intelligent Buffering of Green Power Fluctuation

SPS电盾能源站具备类似“储水罐”、“储气罐”的缓冲能力，实时进行动态“削峰填谷”：吸收存储过剩电能，并在电能短缺时瞬时补电，确保系统电压与频率稳定。

The SPS possesses a buffering capacity analogous to a "water storage tank" or "gas storage tank," performing real-time dynamic "peak shaving and valley filling." It absorbs and stores excess electrical energy and instantaneously supplements power during shortages, ensuring system voltage and frequency stability.





全链路节能降耗

Full-Chain Energy Saving and Consumption Reduction

SPS电盾能源站通过改善绿电质量，提升功率因数、降低线损，并减少因绿电质量问题导致的设备额外能耗（如振动、噪音、温升、摩擦等），综合节电率高达4.14%~13.5%。

By improving the quality of green power, the SPS enhances the power factor, reduces line losses, and decreases the additional energy consumption of equipment caused by power quality issues (such as vibration, noise, temperature rise, friction, etc.). The comprehensive power saving rate reaches 4.14% to 13.5%.



用电设备全周期保护

Full Lifecycle Protection for Electrical Equipment

SPS电盾能源站具备系统保护能力，显著降低用电设备、仪器仪表及开关故障率，延长设备寿命，节约维护成本；同时可削减光伏发电/风力发电/与市电切换过程中的波动与冲击，提升系统运行安全，延长电池寿命，提高光伏发电/风力发电与储能的充放电转化效率。

The SPS provides system-level protection, significantly reducing the failure rate of electrical equipment, instruments, meters, and switches, thereby extending equipment service life and saving maintenance costs. It also mitigates fluctuations and impacts during the switching between photovoltaic/wind power generation/storage power and the grid, enhancing system operational safety, extending battery lifespan, and Enhance the charge-discharge conversion efficiency for power generation/wind power generation and energy storage systems.



电能污染自动治理

Automatic Power Pollution Mitigation

SPS电盾能源站可有效抑制绿电特有的间歇性、随机性波动，以及瞬流、浪涌、谐波等电能污染，确保用电设备接入“纯净、优质”的新型优质电能。

The SPS effectively suppresses the intermittent and random fluctuations characteristic of green power, as well as power pollution such as transients, surges, and harmonics, ensuring that electrical equipment is supplied with new, high-quality electric power that is "clean, and of high-quality".

全天候智能监测预警

All-Weather Intelligent Monitoring and Early Warning

SPS电盾能源站配套的《光储管理平台》与《能耗实时监测&智能预警平台》，实现全流程可视化监控，支持多终端访问，自动向3~5名有关人员推送实时动态信息。

The SPS is supported by both the "PV & Storage Management Platform" and the "Real-time Energy Consumption Monitoring & Intelligent Early Warning Platform." These platforms enable fully visualized, end-to-end monitoring, support multi-terminal access, and automatically push early warning messages to 3-5 designated responsible personnel.



雷击危害主动防御

Proactive Lightning Strike Protection

SPS电盾能源站基于双向阻隔与虚拟电容的缓冲机制，在雷电流试图侵入能源站及用户配电系统时，自动阻隔雷击电流，为雷暴多发区域用户提供额外防雷保护，减少雷击引发的损害及损失。

Leveraging its bidirectional blocking and virtual capacitance buffering mechanisms, the SPS automatically blocks lightning surge currents when they attempt to penetrate the energy station or the user's power distribution system. This provides additional lightning protection for users in lightning-prone areas, effectively reducing related damage and losses.



多源供电平滑切换

Smooth Multi-Source Power Switching

SPS电盾能源站优化光伏电/风电、储能与市电之间的切换过程，以及储能的充放电实现无缝平滑过渡，降低电流电压冲击，保护敏感设备，延长电池与逆变器等设备使用寿命。

The SPS Shield Power Station optimizes the switching process between photovoltaic/wind power, energy storage, and grid power. It achieves a seamless and smooth transition through the charge and discharge cycles of the energy storage system, thereby mitigating current and voltage impacts, protecting sensitive equipment, and extending the service life of components such as batteries and inverters.



04 TECHNICAL PRINCIPLE 技术原理



SPS电盾能源站的技术核心在于三大模块的深度融合。

The technical core of the SPS lies in the deep integration of three key modules.

新型优质电能模块

Advanced and High-Quality Power Module

新型优质电能模块即稳电模块，是SPS电盾能源站的“心脏”，由祥和的抗冲调流型变压器或电保镖——反常安全保护装置组成，其主回路上的纯物理结构的双向阻隔、反常霍尔棒、虚拟电容芯及数字化能耗智能预警平台四大核心技术融合，通过双向阻隔、削减、滤除、吸收机制，从改善和提高绿电质量源头上治理电污染，使SPS电盾能源站输出新型优质电能。

The Advanced and High-Quality Power Module, also known as the Power Stabilization Module, serves as the "heart" of the SPS. It consists of Xianghe's impact-resistant current-regulating transformer or the Xiang He Power Guard—an Abnormal safety protection device. By integrating four core technologies on its main circuit—pure physical bidirectional blocking, an abnormal Hall bar, a virtual capacitor core, and a digital energy consumption intelligent early-warning platform—it employs mechanisms such as bidirectional blocking, suppression, filtering, and absorption to address electrical pollution at its source by improving and enhancing the quality of green power. This enables the SPS to deliver advanced and high-quality power.

系统节能模块

System Energy-Saving Module

作为“效益放大器”，依托新型优质电能系统性提升能效，不仅降低系统线损，还通过降低设备温升、振动、磨擦、噪音和产品废品率，提升整体运营效率，也通过SPS电盾能源站光伏发电/风力发电模块及储能模块充放电及市电转换的平稳度，实现SPS电盾能源站的运行平稳度和效能。

The System Energy Saving Module functions as an "Efficiency Amplifier." By leveraging new, high-quality electric power, it systematically enhances overall energy efficiency. This approach not only reduces system line losses but also improves operational efficiency by lowering equipment operating temperature, vibration, friction, and noise, as well as reducing product defect rates. Furthermore, the stability of the SPS's own operation is reinforced through the smooth charging and discharging processes of its photovoltaic/wind power generation modules and energy storage modules, along with seamless switching between these sources and the grid power.

光伏(风力)发电/现代储电模块

Photovoltaic Power Generation/
Modern Electricity Storage Module

作为SPS电盾能源站的“能量源”与“蓄水池”，通过其光伏发电/风力发电模块发电、储能模块充放电及其提升市电转换的平稳度，实现SPS电盾能源站的运行平稳度和运行效能。

采用行业成熟技术，负责能量的收集与存储，为系统提供绿色动力。关于光伏发电/风力发电模块与现代储电模块的原理，人们已了解和熟悉，这里不再赘述。

Serving as both the "energy source" and "reservoir" for the SPS. By generating electricity through its photovoltaic/wind power modules, managing charge-discharge cycles via the energy storage module, and enhancing the stability of grid power conversion, it ensures the operational stability and efficiency of the entire SPS.

These components employ mature industry technologies responsible for energy collection and storage, supplying the system with green power. As the principles underlying the photovoltaic/wind power generation modules and modern electricity storage modules are already widely understood and familiar, they will not be elaborated further here.



05

PRODUCT CATEGORIES

产品分类



SPS电盾能源站，按用户的常见需求，分为下列三大类

Based on common user requirements, the SPS is classified into the following three main categories



按建设模式分类

Classification By Construction Mode

集中式SPS电盾能源站

Centralized SPS

适用于负荷集中、需统一供电的大型区域或大型项目。

Suitable for large-scale areas or projects with concentrated energy loads that require a unified energy supply.

2

分布式SPS电盾能源站

Distributed SPS

适用于负荷分散、可就近部署的多个用能场景。

Ideal for multiple energy consumption scenarios with dispersed loads where deployment can be implemented locally.



按电网位置分类

Generation-Side SPS Shield Power Station

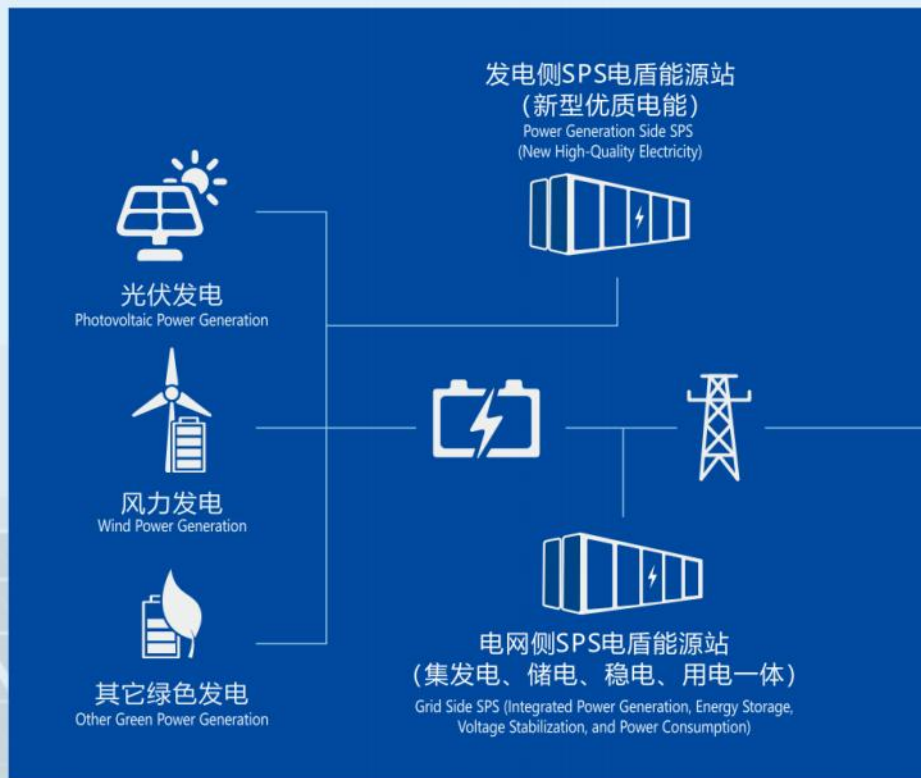
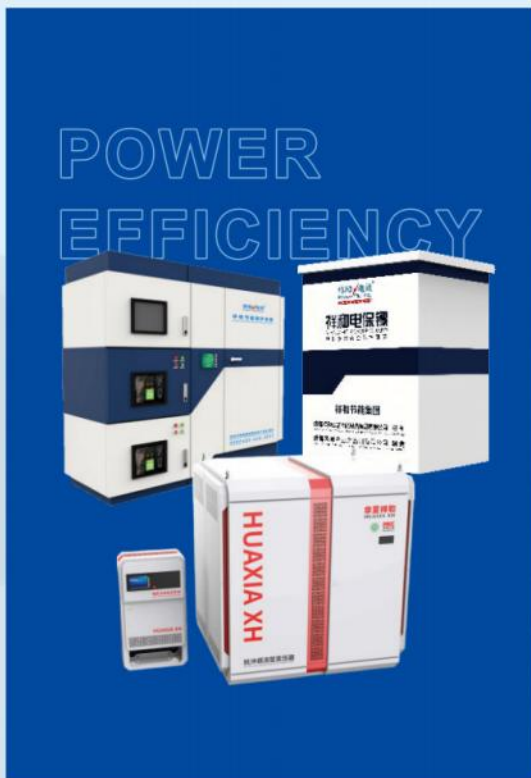

按容量规模分类
Classification By Capacity Scale

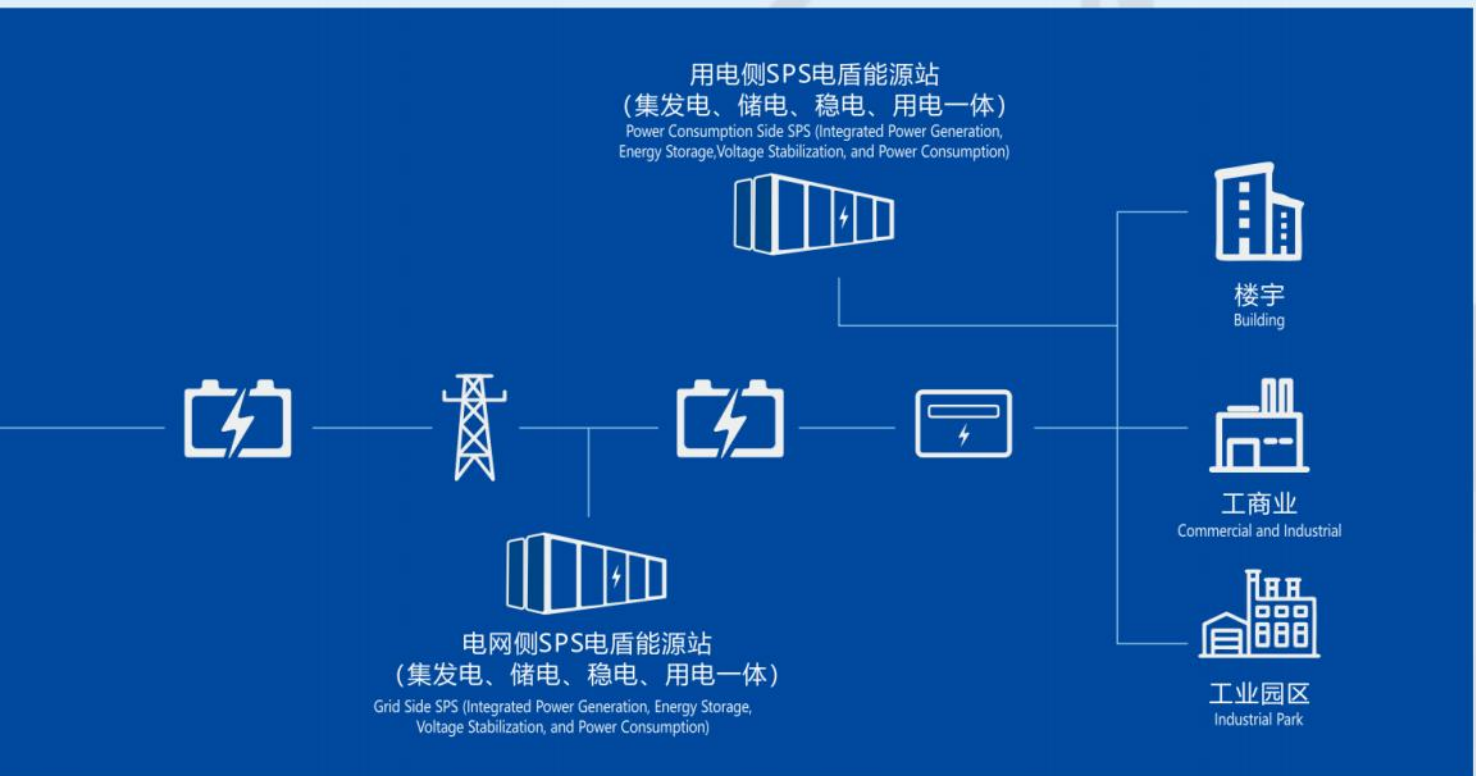

06 TYPICAL APPLICATION SCENARIOS 典型范例





01•

广泛应用于制造业工厂、商业综合体、数据中心、医院等终端用电单位。通过提升电能质量与系统能效，有效保障精密设备稳定运行，显著降低综合能耗与用电成本。可适配微型至大型容量规格。

This model is widely deployed in end-user facilities such as manufacturing plants, commercial complexes, data centers, and hospitals. By enhancing power quality and system energy efficiency, it effectively ensures the stable operation of precision equipment while significantly reducing overall energy consumption and electricity costs. It is adaptable to a range of capacity specifications, from micro to large scale.



02•

主要配套于大型光伏电站、风电场等发电基地。利用储能与电能优化技术，平滑发电出力波动，提升并网友好性与电力外送稳定性。多选用大型至特大型容量规格。

Primarily deployed in conjunction with large-scale power generation bases such as photovoltaic power plants and wind farms. Utilizing energy storage and power optimization technologies, it smoothes output fluctuations, enhances grid compatibility, and improves the stability of power transmission. Typically configured in large to ultra-large capacity specifications.



03•

应用于区域输电网络的关键节点，作为电网的“稳定器”，保障输电过程中的电能质量与传输效率，缓解线路拥堵。主要以特大型容量规格为主，需紧密结合电网整体规划进行部署。

Deployed at critical nodes within regional transmission networks, functioning as grid "stabilizers" to ensure power quality and transmission efficiency, while alleviating line congestion. Primarily implemented in ultra-large capacity specifications, with deployment closely aligned with overall grid planning.

01 用电侧范例 Consumption-Side Applications



重庆某汽车配件公司是一家汽车齿轮和轴承的研发、生产、销售一体化的高新技术企业。2024年6月，该厂投资建设了SPS电盾能源站项目。

该厂为了削减光伏绿电波澜，也为了削减绿电的市电新型电能质量问题，而特地投资了祥和SPS的优质新型电源模块：祥和电保镖——反常安全保护装置，安装在下图所示的位置。

A Chongqing-based automotive parts company is a high-tech enterprise specializing in the R&D, production, and sales of automotive gears and bearings. In June 2024, the factory invested a SPS solution.

To address the challenges of PV generation volatility and the new types of power quality disturbances it introduces to the grid, the facility specifically invested in advanced, high-quality power supply modules from Xianghe SPS: the "Xiang He Power Guard" Abnormal Safety Protection Device, which have been installed at the locations indicated in the following diagram.



02 发电侧范例

Generation-Side Applications



SPS电盾能源站安装在新疆某光伏发电与风力发电融合的集中式发电场的位置如下图：

The SPS is installed at a centralized power plant in Xinjiang, integrating photovoltaic and wind power generation, as shown in the figure below.

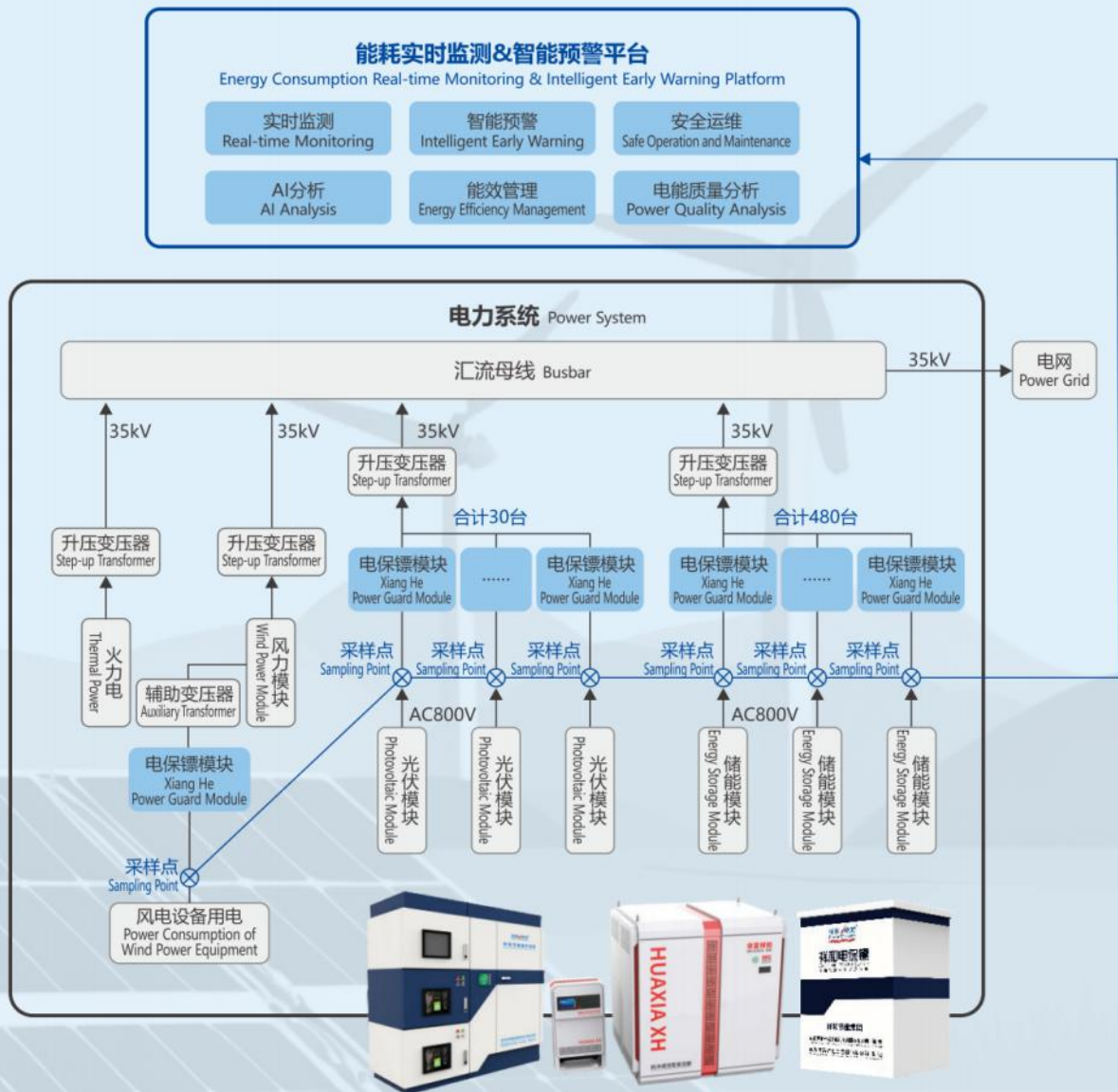



POWER EFFICIENCY

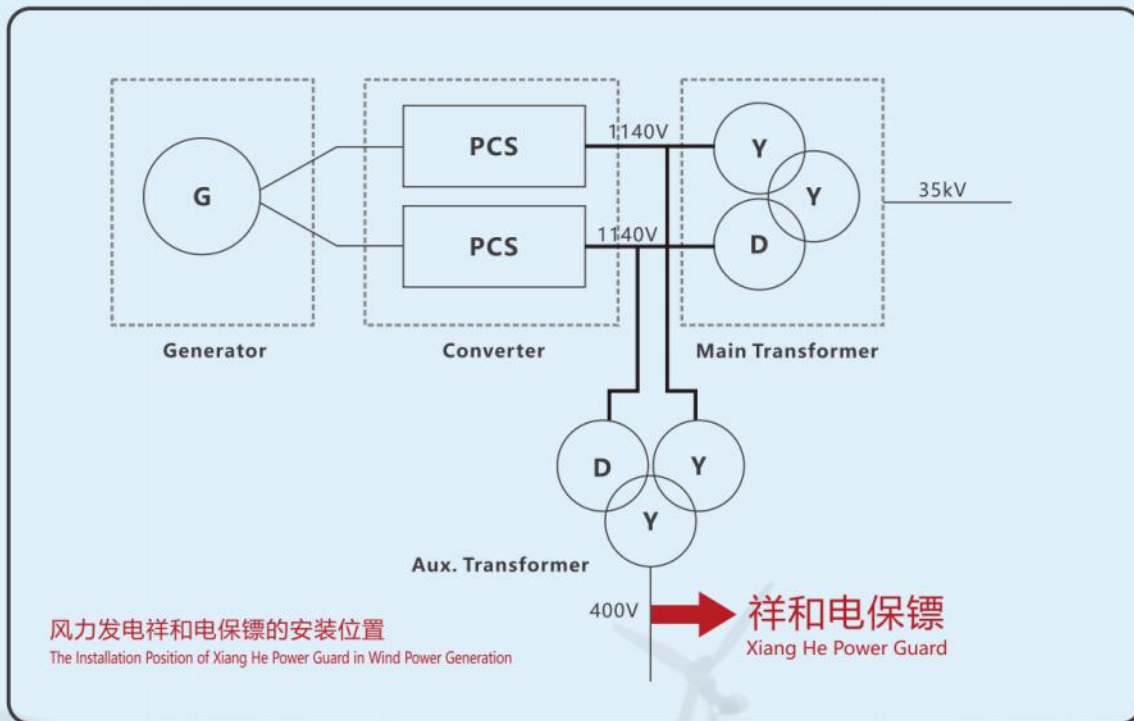

从上图可见，祥和节能集团的SPS电盾能源站，安装在发电侧的核心作用是，轻松实现网格化技术隔离，降低阵风、雷击、沙尘暴等极端条件时的安全风险，削减储能规模化可能的连锁燃烧与爆炸风险，提升储能充放电的平滑性，改善光伏与风电的融合性能，提升绿色并网适配性。

As shown in the figure, the SPS by Xianghe plays a pivotal role in power generation by enabling seamless grid-based technical isolation. This system mitigates safety risks during extreme conditions like gale-force winds, lightning strikes, and sandstorms, while reducing potential chain combustion and explosion hazards in large-scale energy storage. It also ensures smoother energy storage charging and discharging, enhances the integration of photovoltaic and wind power, and improves green grid compatibility.

03

输电侧范例
Transmission-Side
Applications



祥和（四川雅安）应急SPS电盾能源库，是集光伏发电、碲化镉玻璃发电与现代储能一体的应急型能源库，是支撑应急电能供给的“战略储备中心”，祥和抗冲调流型变压器与祥和电保镖——祥和反常安全保护装置，既是削减雷击危害等的网格化技术隔离设备，又是提高余电上网适配性的装置，还是延长储能电池寿命，还是提高光伏电和碲化镉玻璃发电转化率的工具。

The Xianghe Emergency SPS Storage Facility in Ya an, Sichuan, is an emergency energy storage system that integrates photovoltaic power generation, glass-based power generation, and modern energy storage technologies, which serves as a "strategic reserve center" for emergency power supply, it features Xianghe's surge-resistant current-shifting transformers and Xiang He Power Guard—hybrid safety protection devices. These systems not only employ grid-based technical isolation to mitigate lightning hazards but also enhance grid compatibility for surplus power. Additionally, they extend the lifespan of energy storage batteries and improve the conversion efficiency of glass-based solar-photovoltaic power generation.



07 > SOLUTIONS 建设方案

根据不同用户的新能源设施现状，祥和节能集团提供以下三种个性化定制化建设集发电、储电、稳电、用电四位一体的SPS电盾能源站方案：

Based on the current status of users' renewable energy facilities, Xianghe Energy-saving Group offers three personalized and customized construction solutions for the SPS, integrating power generation, storage, stabilization, and consumption into a single system:



方案一： 无基础，全新建

Solution 1:
No Foundation Built, Completely Newly-built From Scratch(Greenfield Deployment)

若您尚未安装任何新能源设施，祥和节能集团可为您提供从建设到运营的一体化解决方案，一步建成完整的SPS电盾能源站。

If you have not yet installed any renewable energy facilities, Xianghe Energy-saving Group can provide an integrated solution from construction to operation, delivering a complete SPS through comprehensive turnkey development.





方案二： 有基础，优化建

Solution 2:
With Existing Foundation, A Comprehensive Upgrade (Brownfield Upgrade)

若您已拥有光伏或储能中的任一新能源站设施，祥和节能集团通过加装核心的电保镖——反常安全保护装置补全设施，助您升级至SPS电盾能源站。

If you already have existing renewable energy facilities, such as photovoltaic or energy storage systems, Xianghe Energy-saving Group can help you upgrade to a full SPS by retrofitting the core Xiang He Power Guard—the Abnormal safety protection device—to augment your current infrastructure.



方案三： 基础全，快速建

Solution 3:
With Existing Pv And Storage, Just An Simple Upgrade (Rapid Retrofit)

若您的光伏和储能设施均已完备，仅需加装祥和节能集团的电保镖——反常安全保护装置，即可快速、经济地完成SPS电盾能源站升级。

If your photovoltaic and energy storage facilities are already fully established, simply installing Xianghe Energy-saving Group's Xiang He Power Guard—the Abnormal safety protection device will enable a quick and cost-effective upgrade to the complete SPS.



08 GROUP PROFILE 集团简介



▲ 祥和节能集团总部大楼
Xianghe Energy-saving Group Headquarters Building



▲ 祥和节能集团生产制造基地
Xianghe Energy-saving Group Production and Manufacturing Base

集团概况

Corporate Profile



祥和节能集团的全称为成都祥和云端节能设备集团有限公司，系国有企业。公司注册资本1.2亿元人民币，总部位于成都高新区高新大道创业路49号。祥和节能集团作为国家级高新技术企业与科技创新型企业，祥和节能集团担任中国能源研究会常务理事单位、四川省节能减碳产业技术创新战略联盟理事长单位，并获评AAA级信用企业，长期深耕于节能设备技术研发与综合能源服务领域。

Xianghe Energy-saving Group, legally registered as Chengdu Xianghe Yunduan Energy Saving Equipment Group Co., Ltd., is a state-owned enterprise. With a registered capital of 120 million Chinese Yuan, the company is headquartered at No. 49 Chuangye Road, Gaixin Avenue, Chengdu High-tech Zone. As a National High-Tech Enterprise and a technology innovation-oriented company, Xianghe Energy-saving Group holds positions including Executive Council Member of the China Energy Research Society and Chairmanship of the Sichuan Industrial Technology Innovation Strategic Alliance for Energy Saving and Carbon Reduction. Rated as an AAA credit enterprise, the group has long been deeply engaged in the fields of energy-saving equipment technology R&D and comprehensive energy services.

POWER EFFICIENCY

双赢企业文化核心理念

Core Philosophy of the Win-Win Corporate Culture

愿景 VISION

致力成为解决新时代
用电问题的领导者；
To strive to become a leader
in solving power usage
challenges in the new era.

使命 MISSION

让用电更安全更省钱；
To make electricity
use safer and more
cost-effective.

价值观 VALUES

为中国碳中和事业
贡献祥和力量，
为世界碳中和事业
贡献中国力量；
To contribute Xianghe's
strength to China's carbon
neutrality cause, and China's
strength to the world's
carbon neutrality cause.

精神 SPIRIT

稳驾绿电波澜，保驭能效节流；
Steering steadily through the
fluctuations of green power,
ensuring control over energy
efficiency and conservation.

理念 PRINCIPLE

安全第一、节能第一、
能效第一、效益第一；
Safety First, Energy Saving First,
Energy Efficiency First, Benefit First.

核心知识产权

Core Intellectual Property



祥和节能集团拥有涵盖发明专利、实用新型专利、软件著作权等在内的完整自主知识产权体系，为SPS电盾能源站提供坚实的技术支撑。以下是部分核心知识产权展示：

Xianghe Energy-saving Group possesses a comprehensive independent intellectual property system covering invention patents, utility model patents, and software copyrights, providing solid technical support for the SPS Shield Power Station. The following is a showcase of some core intellectual property assets:





权威媒体对祥和节能集团技术及项目的报道精选

Selected Coverage of Xianghe Energy-saving Group's Technology and Projects by Authoritative Media



祥和节能集团董事长兼总工程师伍泽涌先生携团队做客CCTV《奋斗》栏目现场图片
Mr.Wu Zeyong, Chairman and Chief Engineer of Xianghe, and his team were invited by the CCTV program "奋斗".



祥和节能集团董事长兼总工程师伍泽涌先生接受CCTV《央央好物》采访现场图

Photo of Mr.Wu Zeyong, Chairman and Chief Engineer of Xianghe during his interview with CCTV's "Yangyang Haowu" program



祥和节能集团董事长兼总工程师伍泽涌先生，应中国光彩科技基金会邀请，于2021年5月19日前往首都北京以领读者的身份，进行了团中央光华书海工程“悦读阅中国”的专场访谈录制。

Mr. Wu Zeyong, Chairman and Chief Engineer of Xianghe Energy-saving Group, was invited by China Glory Science and Technology Foundation to go to Beijing, the capital, on May 19, 2021, to participate in the special interview recording of the Central Committee of the Communist Youth League's Guanghua Book Sea Project "Yue Du Yue Zhong Guo" as a reader.



携手祥和节能集团 开启SPS电盾能源站新纪元

PARTNER WITH XIANGHE ENERGY-SAVING GROUP
USHER IN A NEW ERA WITH THE SPS SHIELD POWER STATION

绿电发得出

Green Power is Reliable Generation

电网接得住

Green Power is Resilient Grid

终端用得好

Green Power is Efficient Consumption

祥和节能集团

XIANGHE ENERGY-SAVING GROUP

成都祥和云端节能设备集团有限公司

CHENGDU XIANGHE CLOUD ENERGY SAVING EQUIPMENT GROUP CO., LTD

Service hotline / 全国统一服务热线: 400-028-3855

Contact number / 联系电话: 15208403491

Official website / 官方网址: www.xhpowerefficiency.com

Company address: No. 49, Chuangye Road, Gaoxin Avenue, Gaoxin District, Chengdu

公司地址: 成都高新区高新大道创业路49号



祥和节能集团官网
www.xhpowerefficiency.com



祥和电盾能源站官网
energystation.xhpowerefficiency.com